

PRODUCT DESCRIPTION

StraightLine SEG display systems feature convenient tool-free assembly, durable light-weight frames, and silicone-edge graphics printed on exclusive One Planet recycled fabrics with impressive vivid graphics, all conveniently organized within molded inserts in a heavy-duty shipping case. Panel A2 is a trapezoid shaped canvas to elevate any messaging into a truly unique display

Upgrade to double-sided graphics, mix-and-match with other StraightLine panels, or combine with WaveLine and BrightLine displays, to create unique branded environments. TV mounts and counters complete an enhanced experience to help brands stand out.

KEY FEATURES

- Modular system
- Easy tool free assembly
- Lightweight portable construction
- Heavy duty shipping case, molded foam inserts
- Single- or double-sided
- Vibrant graphics on recycled fabric

GRAPHIC MATERIAL

Graphic Print :
Dye sublimated on One Planet, 100% recycled, fabric

Bottles recycled
82

DISPLAY CONSTRUCTION

Aluminum frame with aluminum support poles

GRAPHIC FINISHING

Silicone sewn edges

DIMENSIONS

Assembled Unit	118"w1 x 96"w2 x 96"h x 4"d
Packed Case	46.5"w x 15"h x 12"d, 50 lbs
Shipping Box	47"w x 16"h x 13"d, 52 lbs
Graphic Size	118"w x 96"h1 x 96"h2

WARRANTY

Limited Warranty Periods
- Frame : Lifetime
- Graphics : 30 days

PARTS

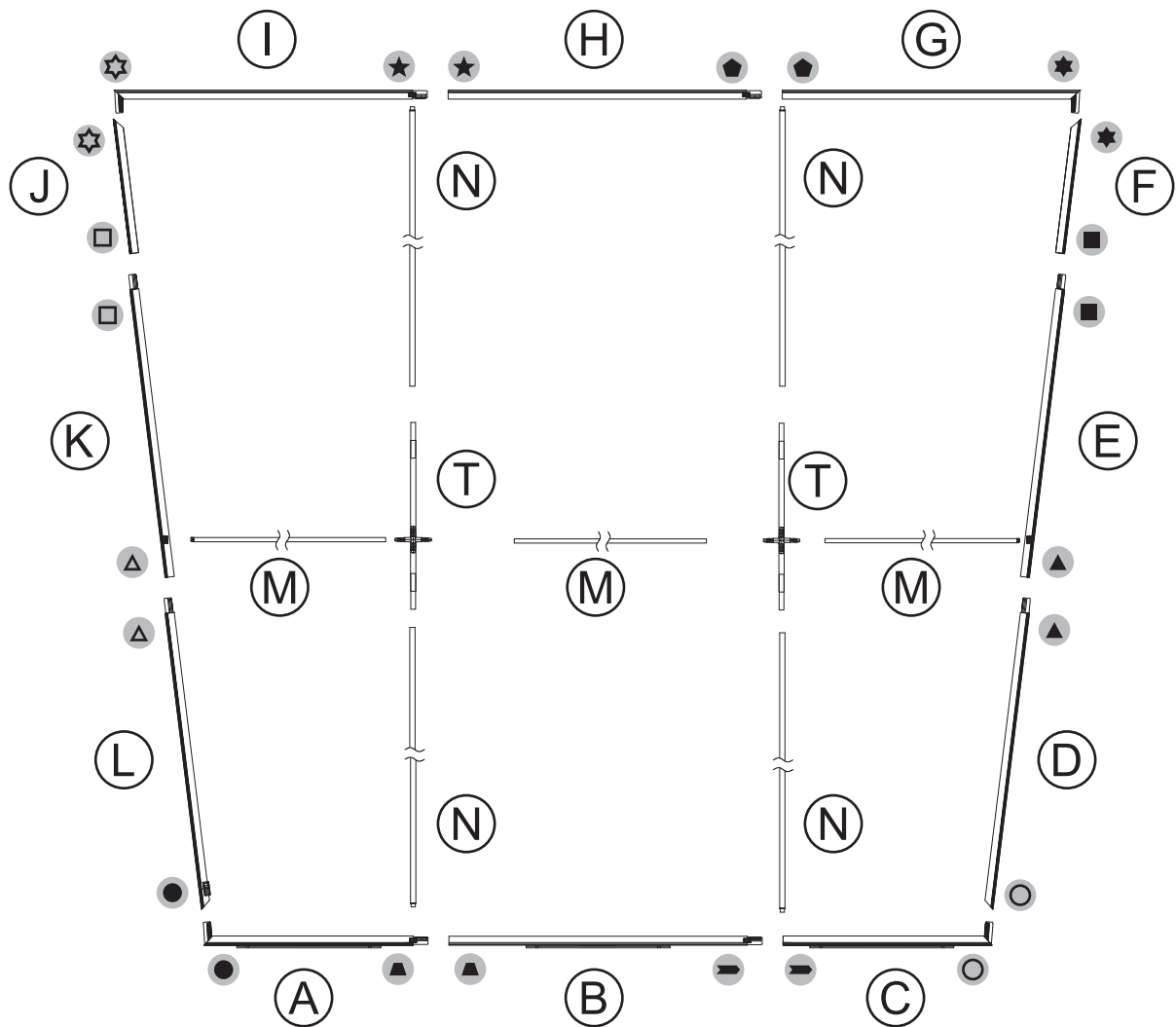
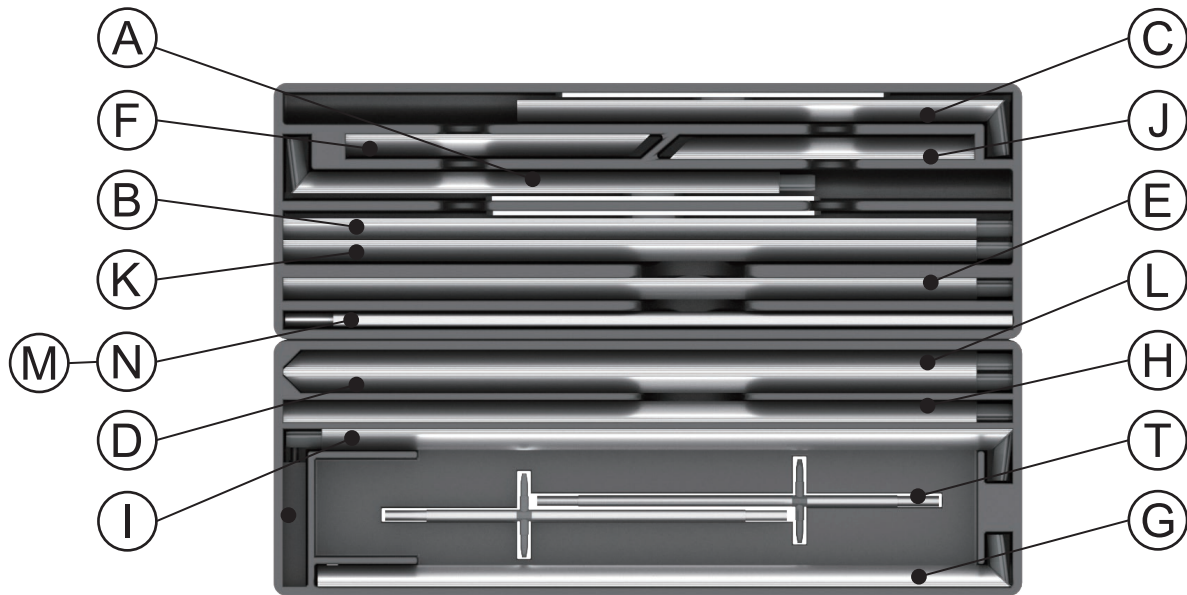

ASSEMBLY

Assemble parts on the floor and stand-up unit when completed.

1

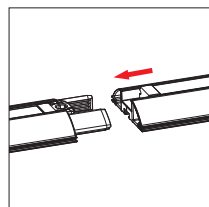

2

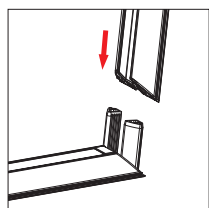

3

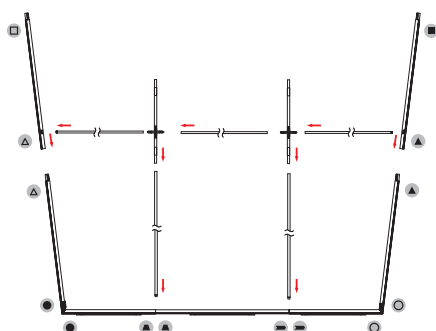
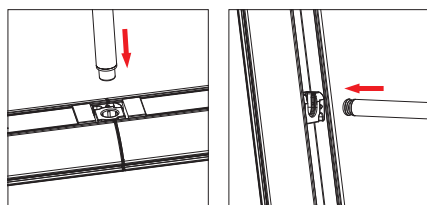

4

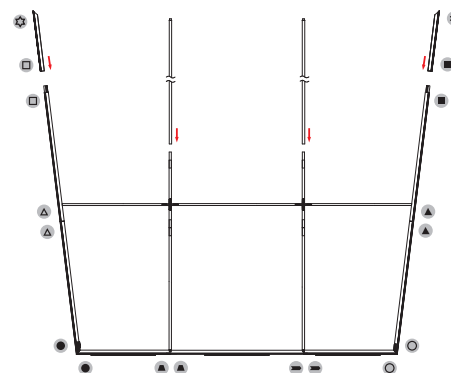
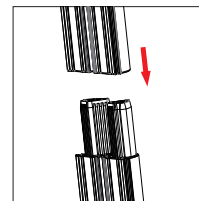

5

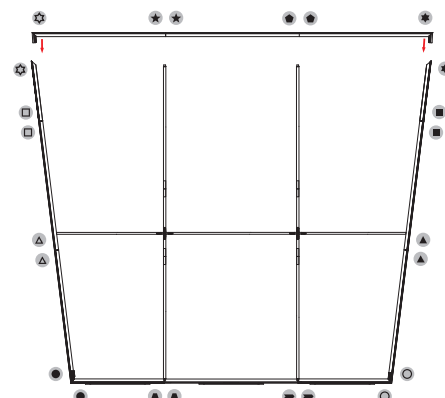
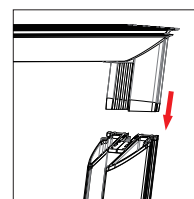

- 6 Push the silicone bead into each corner of the frame with your thumb.

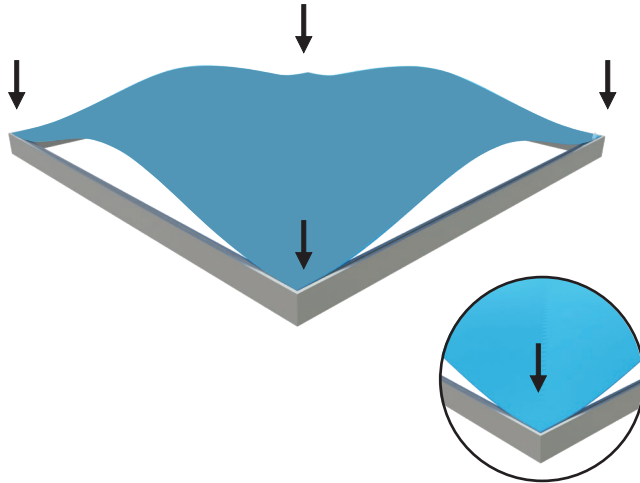

Push the silicone bead into the middle of the run and work your way around the perimeter of the frame until all beading is pushed in properly

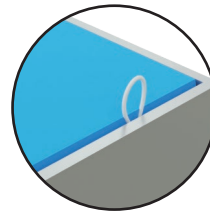
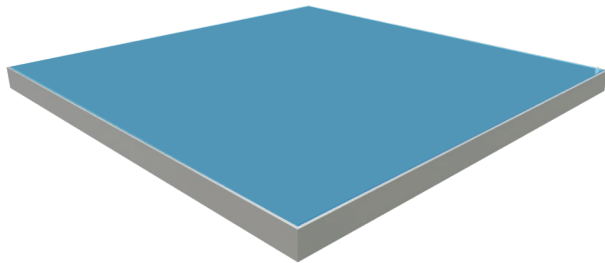
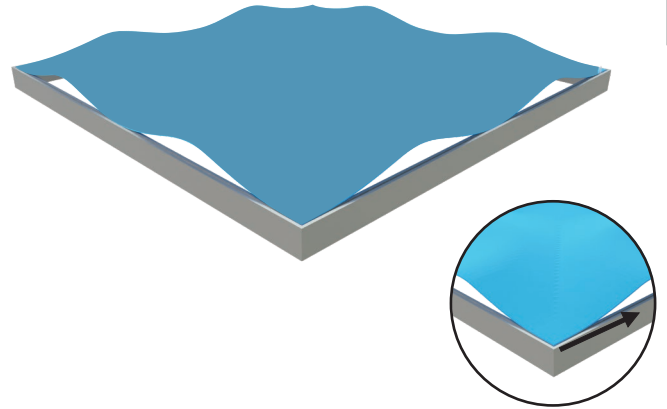

To Remove Graphic

Use the pull tab located on the graphic and gently pull the graphic from the frame, going around the perimeter

- 7

